

OF3-10 Chest Press



Data sheet Karta katalogowa Scheda di dati Fiche Technique Datenblatt

EN

Training effect:

Trains primarily upper parts of muscle. It improves the development of the chest muscles, shoulder girdle and upper limbs.

Regular exercise with a large number of replicates can affect muscle growth.

How to use:

Take a seat on the saddle. Lean and both hands grab bars (vertical or horizontal). Squeeze rods apart and returning to the starting position.

A total safety and functionality of equipment can only be kept when the inspections are made on regular basis. A subject of control should be potential damages and use. Always observe the maintenance and installation guide.

This device is designed for people over 1.4 m tall.

For single person use only. Maximum user's weight 120 kg.

Made followed the EN 16630:2015 norm

Made in Poland

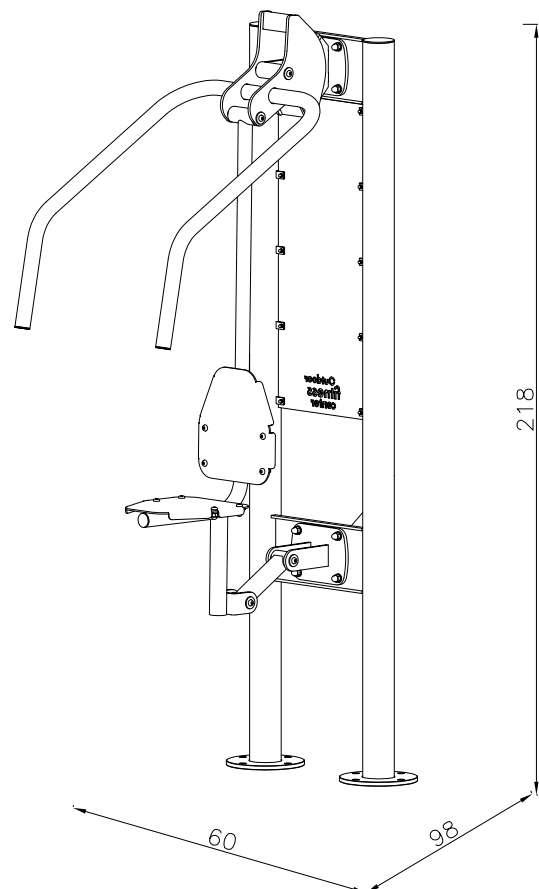
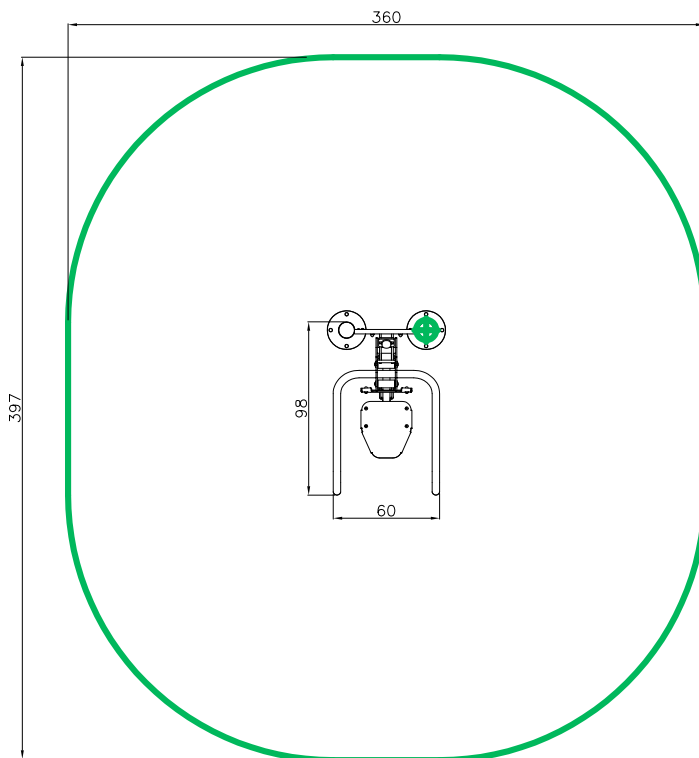



Maintenance manual
Instrukcja konserwacji
Manuel de maintenance
Manuale di manutenzione
Wartungshandbuch

EN A inspection is carried out as follows:

Routine inspection:

Visual inspection device is intended to detect visible damage and risks that could arise for reasons such as: misuse, vandalism or weather conditions.

NOTE 1 For outdoor fitness installed in areas with intensive use of equipment, and also in areas characterized to frequent damage caused by vandalism, may be required daily inspection.

NOTE 2 During the inspection routine and operational should pay attention to: cleanliness, level ground state of the ground, exposed (mobile) foundations, sharp edges, missing parts, excessive used (mobile and disperse the parts), structural strength of construction.

Operational control:

More accurate than a routine inspection of facilities for checking the functionality and stability of exercise equipment. You should do this every 1 to 3 months according to guidance of manufacturer

Main annual inspection:

Control of defining the overall condition for safe exploiting of equipment (main annual review).

NOTE 3 Main annual inspection may need to dig or decompose (spin) of individual equipment or their parts.

The annual inspection should be performed by the manufacturer or an authorized repairer Outdoor Fitness Center. Submissions annual inspection the following address:
fitness@outdoorfitness.pl

Failures

In the absence of damage or exploiting of the device must be immediately replaced or repaired. If this is not possible, secure the unit before use. Contact the site Outdoor Fitness Center: fitness@outdoorfitness.pl.

Use only original spare parts. Repair and replacement of parts may only make the manufacturer or its authorized representative.

OF3-10 Chest Press

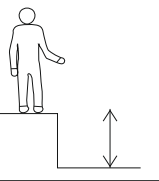
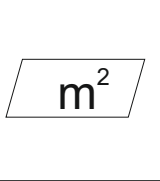
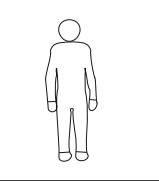

Installation manual
Instrukcja instalacji
Manuel d'installation
Manuale di installazione
Installationshandbuch

		
0,60 m	12,4 m ²	1,4m → +

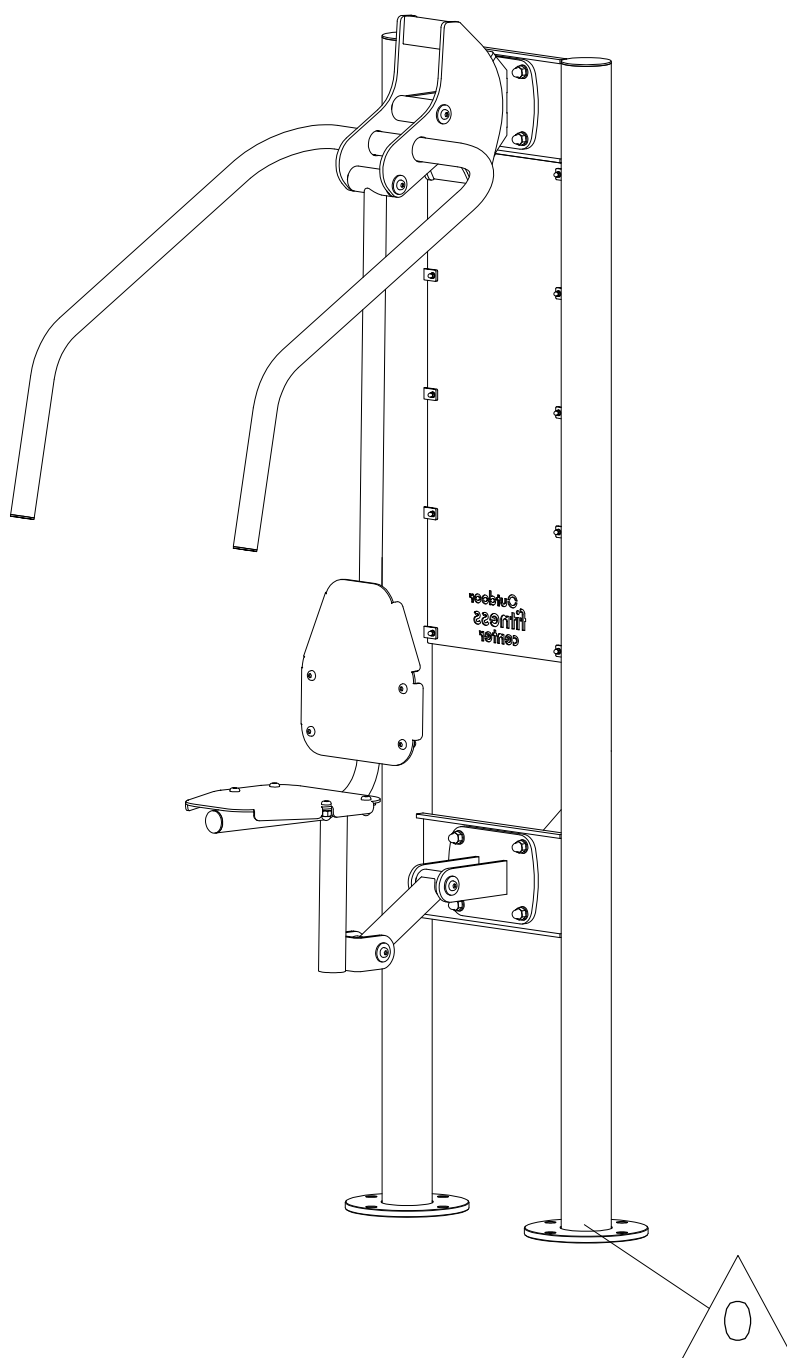

OF3-10 Chest Press



Impact Area
Strefa upadku
Zone d'Impact
Area de Impacto
Fallraum

12,4 m²

Required surface: lawn, bark mulch, woodchip, sand, gravel
Wymagana nawierzchnia: gleba, trawnik, mulcz z kory, drobno pokrojone kawałki drewna, piasek, żwir

Requis de surface: la pelouse, le paillis d'écorce, copeaux de bois, sable, gravier

Superficie necessaria: erba, pacciame di corteccia, finemente tritato pezzi di legno, sabbia, ghiaia

Erforderliche Oberflächen: Gras, Rindenmulch, fein gehackt Holzstücke, Sand, Kies

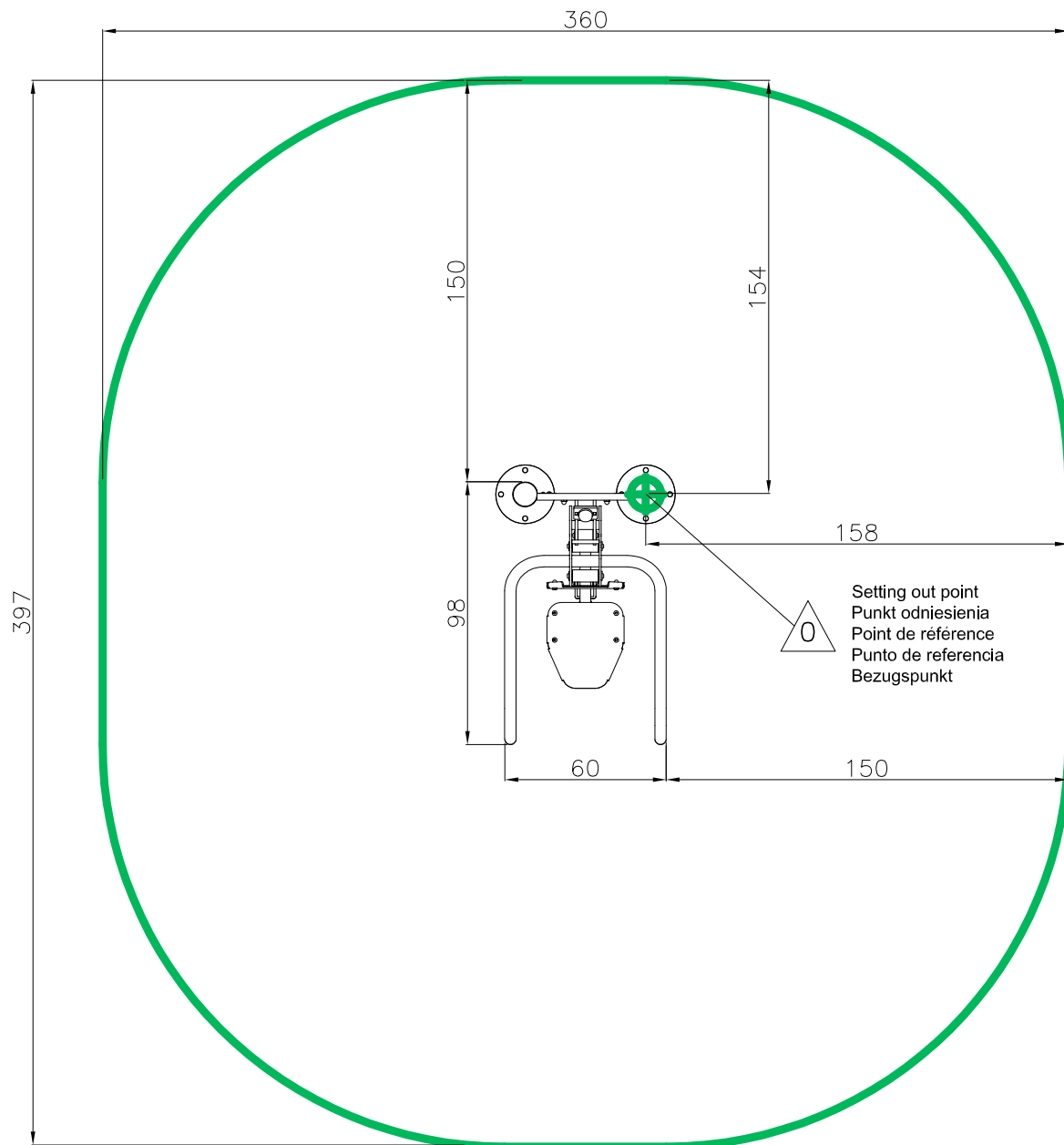

OF3-10 Chest Press



Concrete pad
Fundament betonowy
Dalle béton
Solera de Hormigón
Beton Bodenplatte

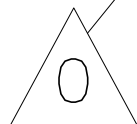
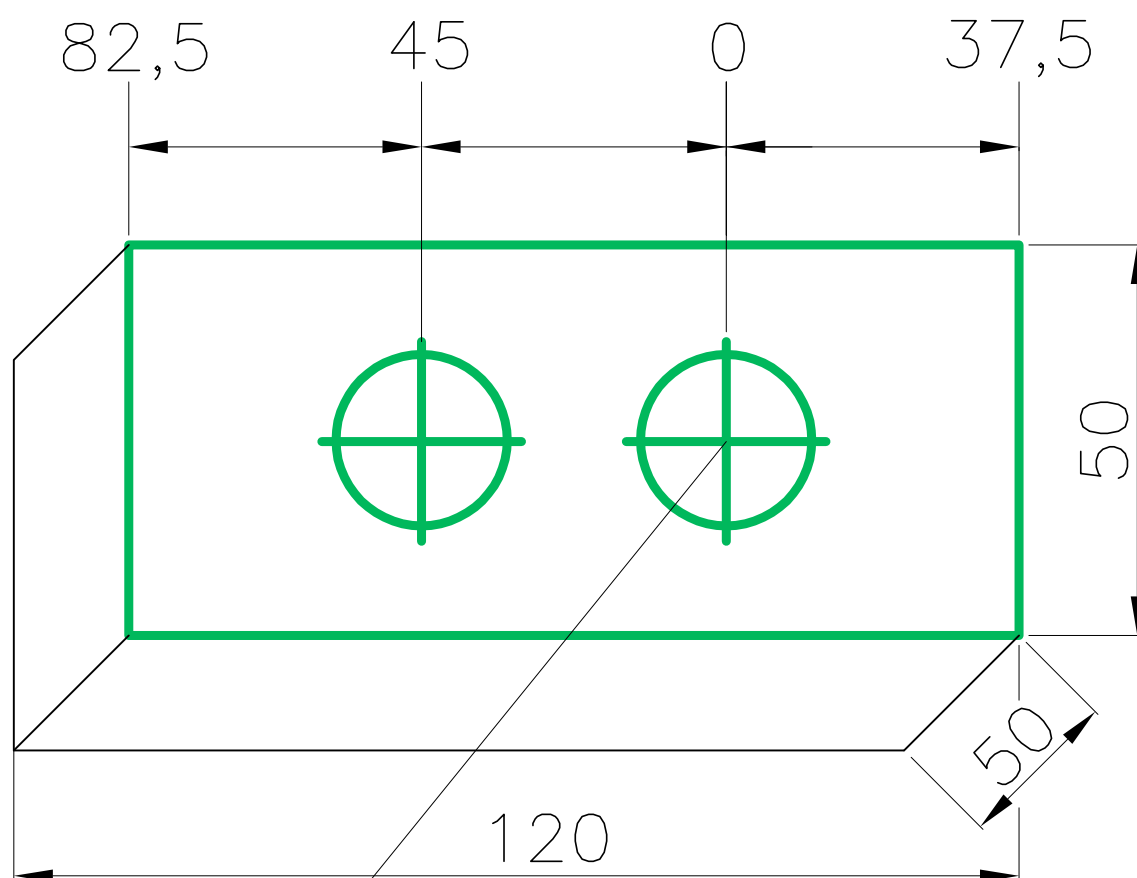

Setting out point
Punkt odniesienia
Point de référence
Punto de referencia
Bezugspunkt





OF3-10 Chest Press

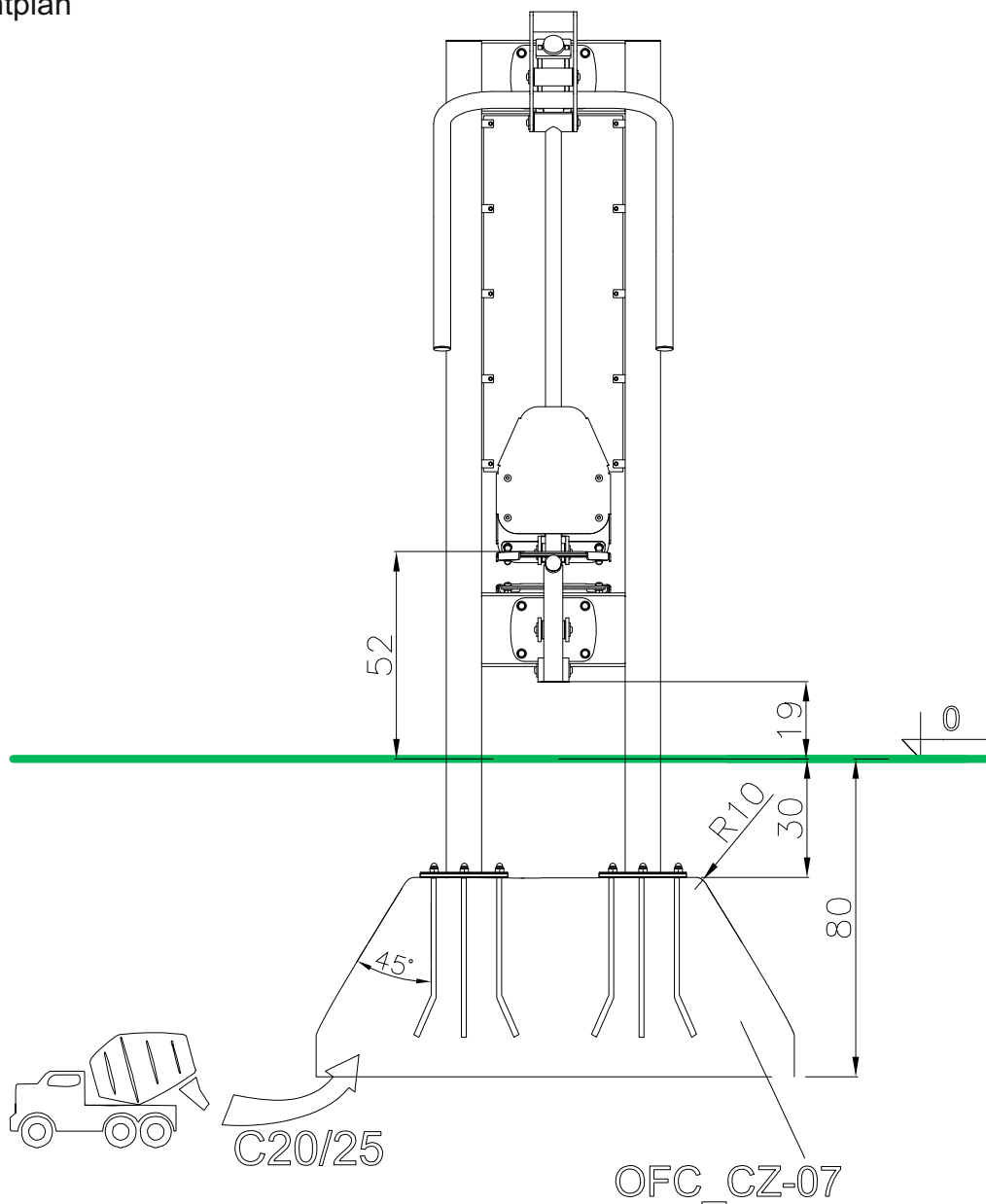

Footing plan
 Plan fundamentowania
 Implanation
 Implanación
 Fundamentplan

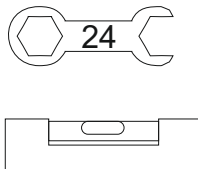

Dimensions are in centimeters

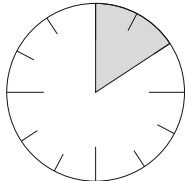
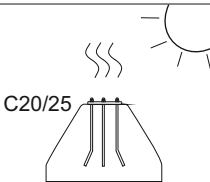
<p>4xM16</p> 	<p>4xM16</p> 	 <p>24</p>	<p>2x</p> 		 <p>Min. 48h</p>
--	--	---	---	---	---

OF3-10 Chest Press





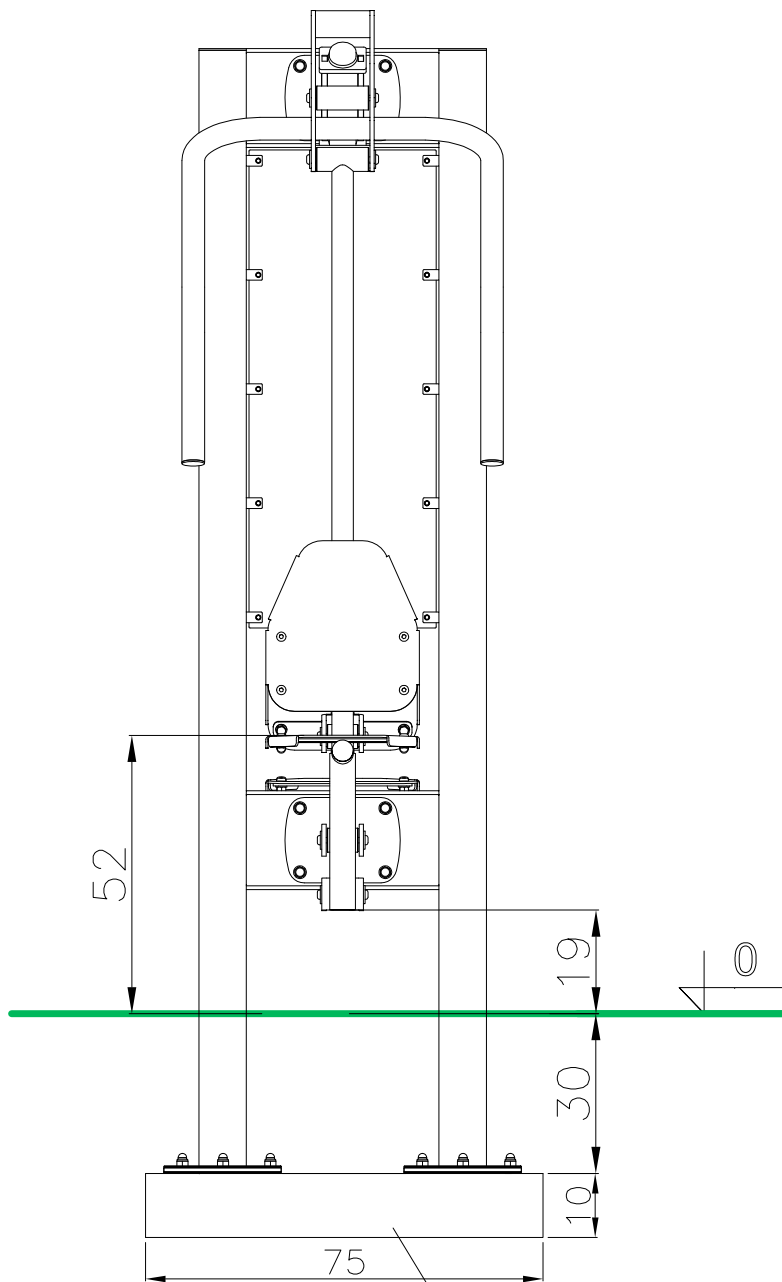

Footing plan
 Plan fundamentowania
 Implanacion
 Implanación
 Fundamentplan

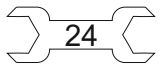
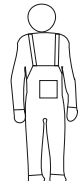
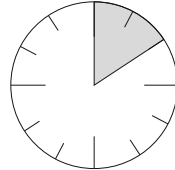

PRF-2

Dimensions are in centimeters

<p>8xM16</p> 	<p>8xM16</p> 	<p>24</p> 	<p>2x</p> 		<p>C20/25</p>  <p>Min. 0h</p>
--	--	---	---	---	--