

Data sheet

A device for playing outdoors

Made based on the standard PN-EN 1176-1:2017-12

Manufactured in Poland

Technical data

- Device size:	0,97 x 0,26 m
- Total height:	0,86 m
- Impact area dimensions:	3,97 x 3,26 m
- Impact area:	10,92 m ²
- Free fall height (HIC):	0,45 m
- Age:	0-3, 3+



Available colors



Device and impact area dimensions

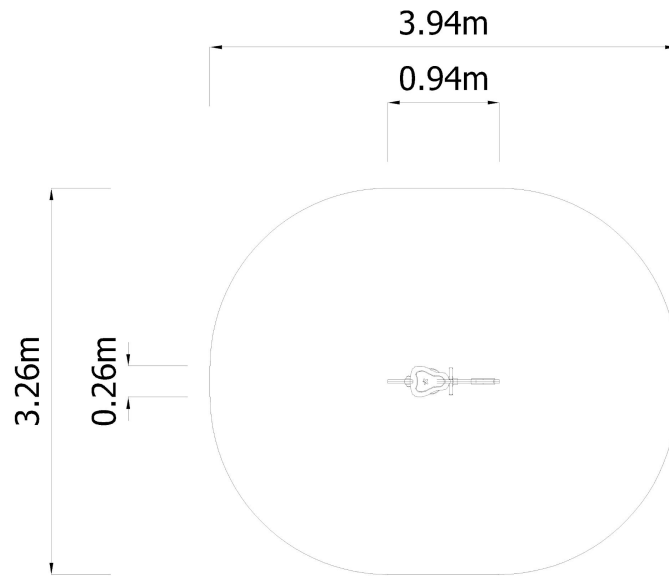

Height

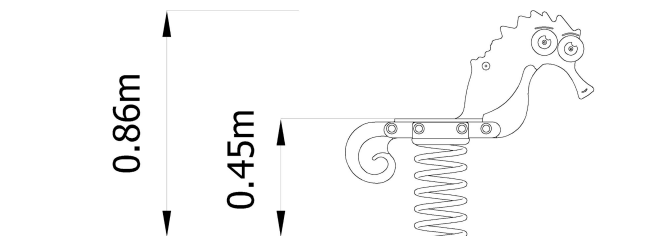

Material specification:

Construction:	certified spring, powder coated
Bars / ladders:	stainless steel
Connections:	stainless steel
Seat:	weatherproof HDPE
Applications:	weatherproof HDPE
Anchor:	devices permanently anchored in the ground on a concrete foundation of min. C20/25, 35 cm below the ground level

Impact attenuating surface:

It is required to make one of the impact attenuating surface:

Grass

Sand – 0,2 - 2 mm grain size, depth min. 200 mm,

Gravel – 2 - 8 mm grain size, depth min. 200 mm,

Bark – 20 - 80 mm particle size, depth min. 200 mm,

Woodchips – 5 - 30 mm particle size, depth min. 200 mm,

Other materials and other depths as tested according to EN 1178

