

Data sheet  
Karta katalogowa  
Scheda di dati  
Fiche Technique  
Datenblatt

EN

**Training effect:** Aids the activity of hip joints and of the lumbar spine. Trains the sense of balance and affects the abdomen muscles.

**Method of use:** 1) Take a position on one of the disc with both legs, grab the holder with your hands and then move your hips in a uniform fashion from the right side to the left.  
2) Take a sit, grab the holder with your hands and then move from the right side to the left.

**Exercise difficulty:** Easy

Full safety of the equipment use can be maintained only as a result of regular control concerning damage and wear. Devices should be regularly checked for security and functionality.  
Fitness device for youth over 1,4 m.

Intended for one person. Maximum weight of user 100 kg.

Prepared on the basis of the following standards: PN-EN 16630: 2015

Manufactured in Poland.

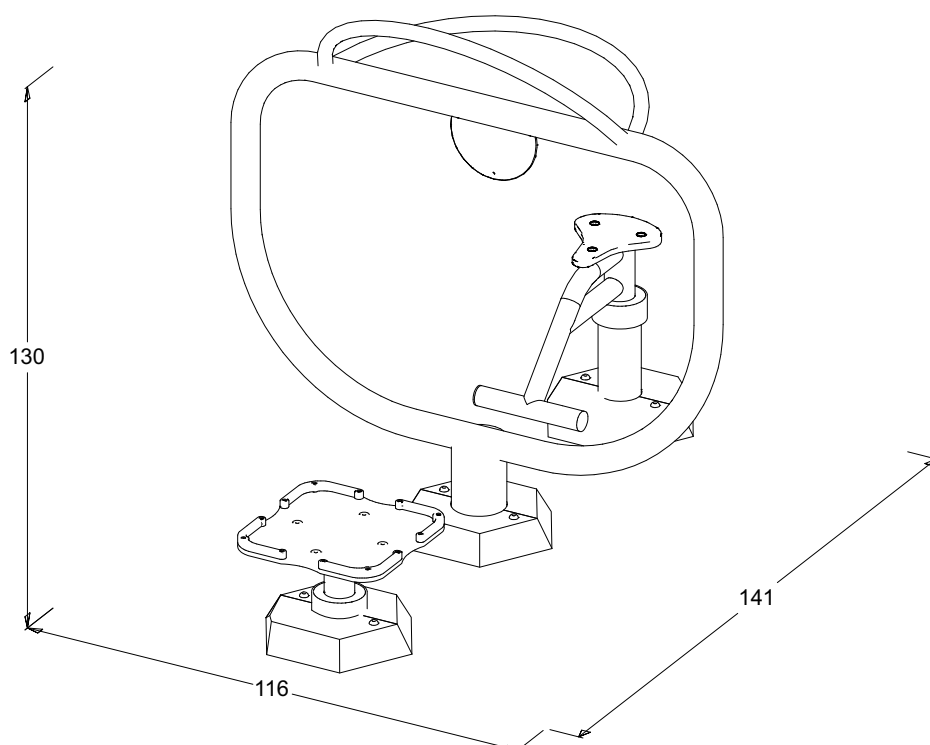

**Maintenance manual**  
**Instrukcja konserwacji**  
**Manuel de maintenance**  
**Manuale di manutenzione**  
**Wartungshandbuch**

**EN** A inspection is carried out as follows:

**Routine inspection:**

Visual inspection device is intended to detect visible damage and risks that could arise for reasons such as: misuse, vandalism or weather conditions.

NOTE 1 For outdoor fitness installed in areas with intensive use of equipment, and also in areas characterized to frequent damage caused by vandalism, may be required daily inspection.

NOTE 2 During the inspection routine and operational should pay attention to: cleanliness, level ground state of the ground, exposed (mobile) foundations, sharp edges, missing parts, excessive used (mobile and disperse the parts), structural strength of construction.

**Operational control:**

More accurate than a routine inspection of facilities for checking the functionality and stability of exercise equipment. You should do this every 1 to 3 months according to guidance of manufacturer

**Main annual inspection:**

Control of defining the overall condition for safe exploiting of equipment (main annual review).

NOTE 3 Main annual inspection may need to dig or decompose (spin) of individual equipment or their parts.

The annual inspection should be performed by the manufacturer or an authorized repairer Outdoor Fitness Center. Submissions annual inspection the following address: [fitness@outdoorfitness.pl](mailto:fitness@outdoorfitness.pl)

**Failures**

In the absence of damage or exploiting of the device must be immediately replaced or repaired. If this is not possible, secure the unit before use. Contact the site Outdoor Fitness Center: [fitness@outdoorfitness.pl](mailto:fitness@outdoorfitness.pl).

Use only original spare parts. Repair and replacement of parts may only make the manufacturer or its authorized representative.

**Impact Area**  
**Strefa upadku**  
**Zone d'Impact**  
**Area de Impacto**  
**Fallraum**



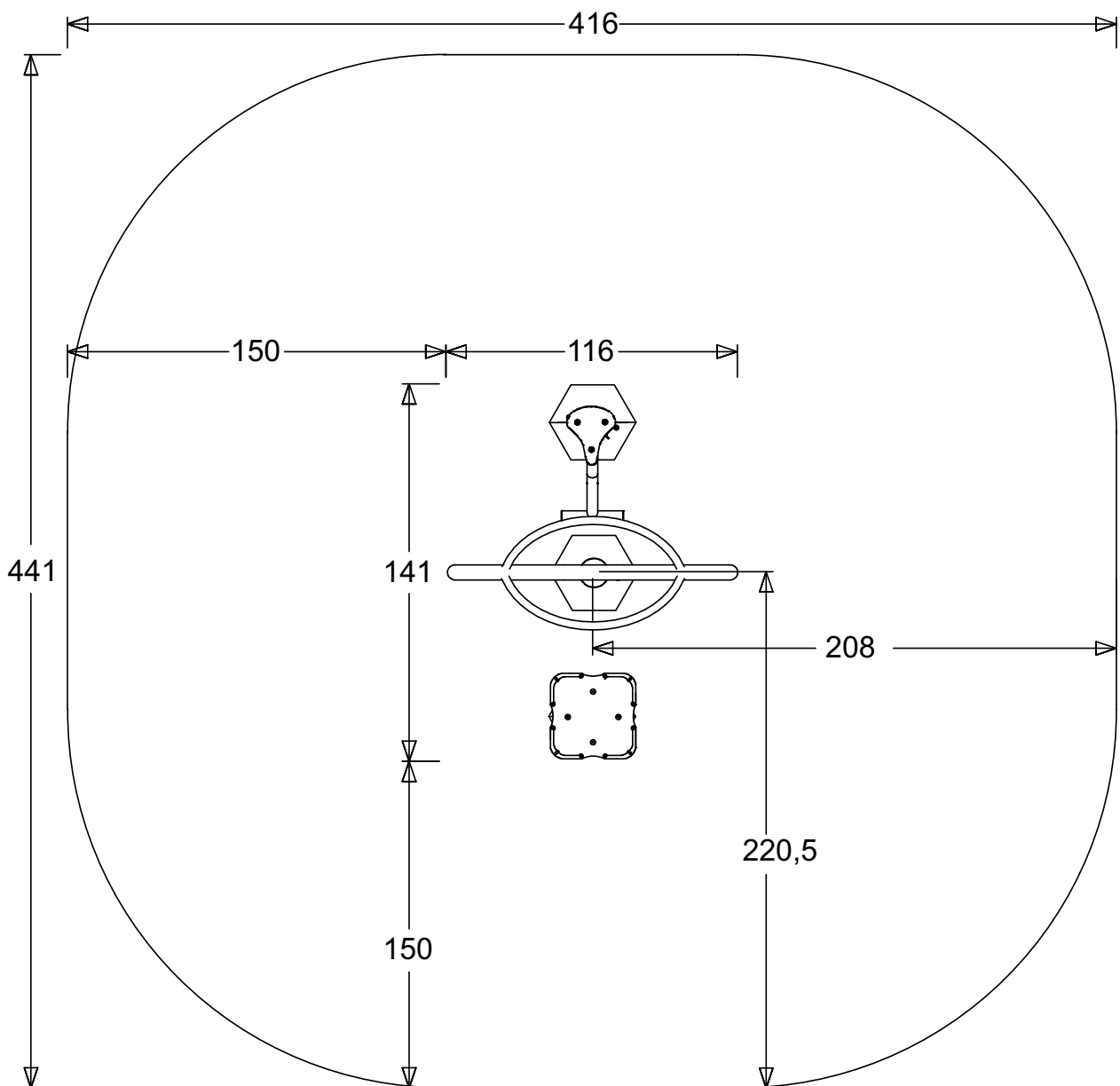

Required surface: lawn, bark mulch, woodchip, sand, gravel  
 Wymagana nawierzchnia: gleba, trawnik, mulcz z kory, drobno pokrojone kawaiki drewna, piasek, żwir  
 Requis de surface: la pelouse, le paillis d'écorce, copeaux de bois, sable, gravier  
 Superficie necessaria: erba, paccime di corteccia, finemente tritato pezzi di legno, sabbia, ghiaia  
 Erforderliche Oberflächen: Gras, Rindenmulch, fein gehackt Holzstücke, Sand, Kies

# 18,3 m<sup>2</sup>

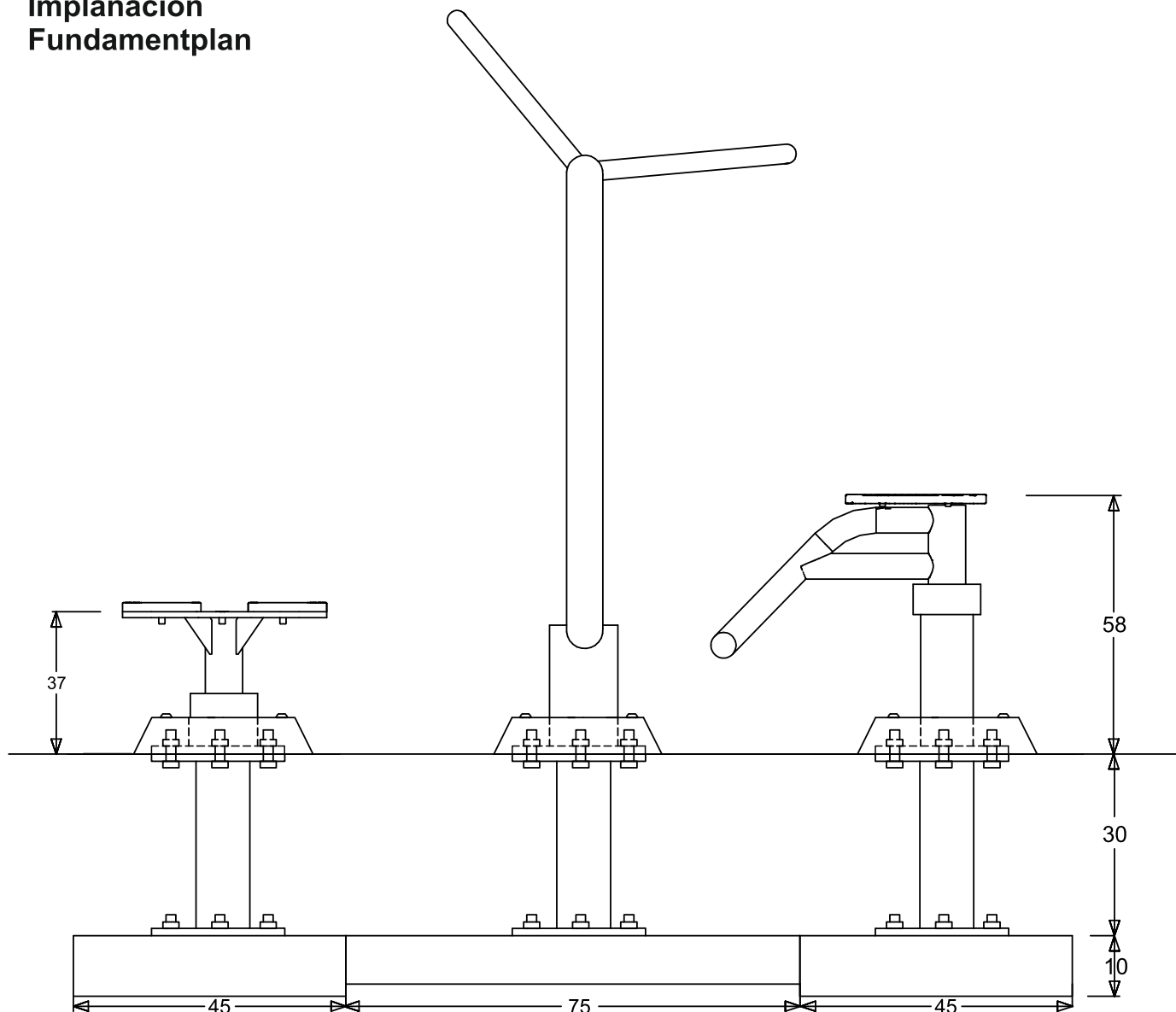



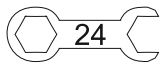

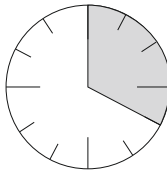
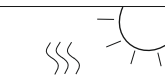
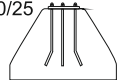

**Footing plan**  
**Plan fundamentowania**  
**Implanation**  
**Implanación**  
**Fundamentplan**

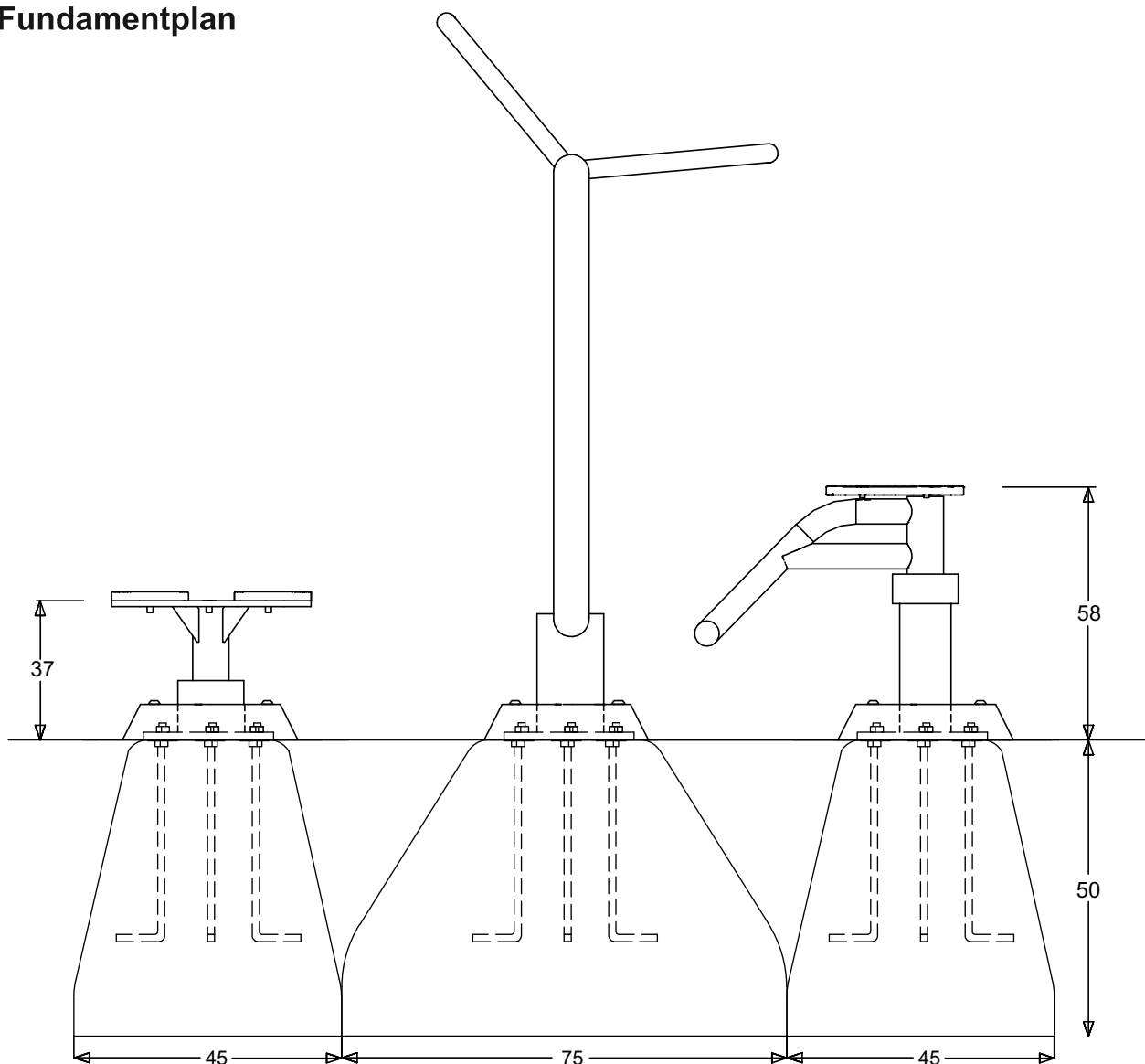

<p>4xM16</p> 	<p>4xM16</p> 	 <p>24</p> 	<p>2x</p> 		 <p>C20/25</p>  <p>Min. 48h</p>
--	--	---	---	---	---

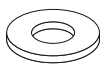
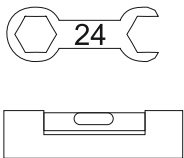
**Footing plan**  
**Plan fundamentowania**  
**Implanation**  
**Implanación**  
**Fundamentplan**

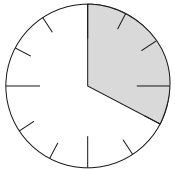

<p><b>4xM16</b></p> 	<p><b>4xM16</b></p> 	<p><b>24</b></p> 	<p><b>2x</b></p> 		<p><b>C20/25</b></p>  <p><b>Min. 0h</b></p>
---	---	--	--	---	--